

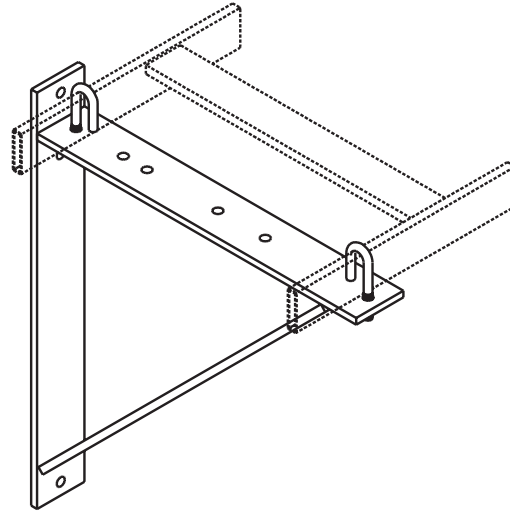

CHATSWORTH
PRODUCTS

Triangular Support Bracket, Aluminum



Triangular Support Bracket, Aluminum

Triangular Support Bracket provides wall support for Cable Runway. Made of 1/4" x 2" (6.4 mm x 50 mm) aluminum bar. Load rating is 100 lb (45.4 kg).

- Compatible with Adjustable Cable Runway

Kit includes:

- (1) triangular bracket
- (2) 5/16-18 x 2 1/4" J-bolts
- (2) 5/16-18 hex nuts & 5/16 lock washers

ORDERING INFORMATION

Part Number	Runway Widths in (mm)	Shipping Weight lb (kg)
11312-X06	4-6 (100 - 150)	2 (0.9)
11312-X12	6-12 (150 - 300)	3 (1.4)
11312-X18	12-18 (300 - 460)	3 (1.4)

X=color: 1=Gray, 7=Black, E=Glacier White

United States & Canada
Simi Valley, CA
800-834-4969
Toronto, Ontario, Canada
+905-850-7770
chatsworth.com
techsupport@chatsworth.com

Latin America
Mexico City, Mexico
+52-55-5203-7525
Toll Free within Mexico
800-201-7592
chatsworth.com.co

Europe
Buckinghamshire
England, UK
+44-1628-524-834

Middle East & Africa
Dubai, UAE
+971-4-2602125
Doha, Qatar
+974-4-267422

Asia Pacific
Jing'an District,
Shanghai, China
+86 21 6880-0266
chatsworth.com.cn