

EF-Series EuroFrame® Gen 2 Cabinet System User Manual



CHATSWORTH
PRODUCTS

chatsworth.com
+44 1628 524-834 (UK)

©2023 Chatsworth Products, Inc. All rights reserved. Chatsworth Products, Clik-Nut, CPI, CPI Passive Cooling, CUBE-iT, Secure Array, eConnect, Evolution, GlobalFrame, MegaFrame, QuadraRack, RMR, Saf-T-Grip, SeismicFrame, SlimFrame, TeraFrame, Motive and Velocity are federally registered trademarks of Chatsworth Products. EuroFrame, H-Plane, Hi-Bar, In-Plane, M-Frame, NetPoint, Oberon, Simply Efficient, Skybar, Wi-Tile and ZetaFrame are trademarks of Chatsworth Products. All other trademarks belong to their respective companies. 06/23 MKT-60020-655.en-GB

Contents

- EF-Series EuroFrame Cabinet Overview 2**
 - Introduction to the EF-Series EuroFrame Cabinet 2
 - Safety Information..... 2
 - Intended Use..... 5
 - Components of the EF-Series EuroFrame Cabinet..... 5
 - Included Hardware..... 7
- Getting Started 7**
 - Tools Required 9
 - Unpacking 9
- Installation 9**
 - Moving the Cabinet..... 9
 - Anchoring the Cabinet on the Floor 10
 - Bonding the Cabinet to the Telecommunications Ground..... 11
 - Baying Cabinets Together..... 12
- Configuring the Cabinet 13**
 - Removing and Installing the Front Door 14
 - Removing and Installing the Rear Doors 15
 - Removing and Installing the Top Panel 16
 - Removing and Installing the Side Panels 17
 - Adjusting the Equipment Mounting Rails 18
 - Installing Equipment 19
 - Cable Management 20
- Accessories 20**
 - Cable Management 21
 - Power Management 22
 - Thermal Management 23
 - Shelves, Trays and Other Accessories..... 23
 - Service Parts..... 24

EF-Series EuroFrame Gen 2 Cabinet Overview

Introduction to the EF-Series EuroFrame Gen 2 Cabinet

The EF-Series EuroFrame® Gen 2 Cabinet System from Chatsworth Products (CPI) has been developed to meet a wide range of application needs. The cabinet is available in two (2) widths, three (3) heights and three (3) depths.

Cabinet widths:	600 mm (23.6")	800 mm (31.5")
-----------------	-------------------	-------------------

Cabinet heights:	42U	45U	47U
------------------	-----	-----	-----

Cabinet depths:	800 mm (31.5")	1000 mm (39.4")	1200 mm (47.2")
-----------------	-------------------	--------------------	--------------------

The EF-Series EuroFrame Gen 2 Cabinet accessories, including cable management, power management, thermal management and more, offer additional flexibility, enabling the cabinet to be further configured to support many different applications.

Safety Information

Keep a printed copy of this User Manual, especially the following safety information, in or near the cabinet.



WARNINGS:

- Improper use of this product may lead to serious injury or death. Read and understand all instructions for proper installation and use of this product.
- Be sure to use sufficient personnel to safely remove the cabinet from the pallet.
- Do not attempt to move large cabinets by yourself. Obtain adequate assistance to stabilize the cabinet during movement or hire professional equipment riggers.
- Move cabinets on installed casters with extreme care. Sudden stops, excessive force, and uneven surfaces may cause the cabinet to overturn. It is easier to move the cabinet with the back as the leading edge. Never push on the sides.

Safety Information, continued



WARNINGS (continued):

- Unload equipment from the cabinet before moving it.
- A standalone cabinet should be level, stable, and anchored to the floor. Two or more cabinets can be bayed together (coupled) to enhance their stability. Each cabinet should be anchored to the floor.
- Before loading equipment in the cabinet, be sure to adjust and lock the leveling feet to level the cabinet. Do not use casters to stabilize the cabinet; always anchor the leveling feet or the cabinet frame to the floor.
- Always load heavy equipment, such as a UPS, at the bottom of the cabinet first, and add lighter equipment on higher levels.

- There is a safety risk when equipment is mounted on a shelf installed more than 30 inches (760 mm) above the floor in a cabinet without doors and/or side panels. The equipment may accidentally slide or be accidentally pushed off the shelf and fall on personnel. When equipment is mounted on a shelf in this condition, securely fasten the equipment to the shelf or cabinet frame.
- The cabinet can support many system configurations. The amount of force required to tip or make the cabinet unstable differs with each configuration. Be sure to read and follow your equipment manufacturer's specific assembly, installation, and safety instructions.
- When servicing slide-mounted equipment such as servers:
 - Secure all equipment, other than the unit being serviced, in position to prevent it from sliding out and destabilizing the cabinet.
 - Extend only one unit at a time. Extending multiple units may cause the cabinet to tip over.
 - Extend the unit slowly. Rapid deployment of the unit could cause the cabinet to tip over.
- For protection of the equipment and personnel, ground each cabinet individually to the Telecommunications Equipment Bonding Conductor (TEBC) or Signal Reference Structure (SRS).

Intended Use

Keep a printed copy of the Preface of this User's Manual in or near the cabinet.

- Install the cabinet only in a restricted service environment, such as a data center.
- Use indoors only, in environmentally controlled areas; do not use outdoors, in harsh environments,
or in air-handling spaces.
- Allow only qualified service personnel to use the cabinet.
- The cabinets must be leveled on the floor to ensure stability and a safe working environment.
- The load-bearing capacity of the EF-Series EuroFrame Gen 2 Cabinet is:

Static: 1500 kg (3300 lb)



CAUTION: The transport casters provided with the EF-Series EuroFrame Gen 2 are only intended to support the movement of the cabinet when the cabinet is empty.

- The ambient temperature operating range for the EF-Series EuroFrame Gen 2 Cabinet and installed cabinet accessories is 0° to 60°C (32° to 140°F).

Components of the EF-Series EuroFrame Gen 2 Cabinet :

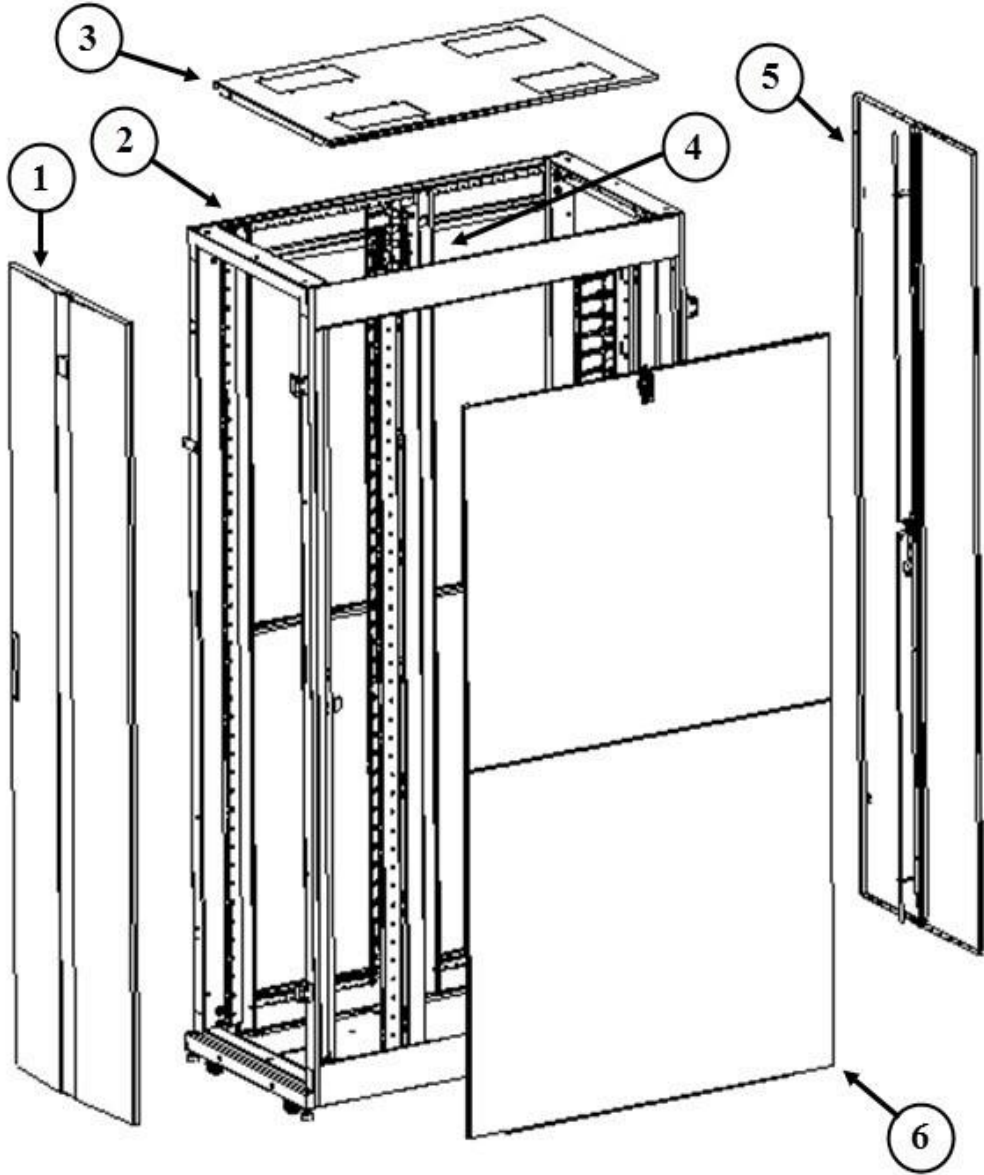

- 1. Frame Door
- 2. Frame
- 3. Standard Top Panel
- 4. Equipment Mounting Rails
- 5. Double Rear Door
- 6. Side Panel

Included Hardware

1. (2) Keys

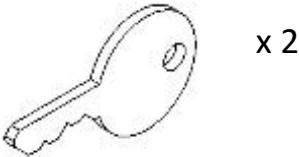

2. (4) Baying Brackets + (8) M6x16 Flat Head Screws

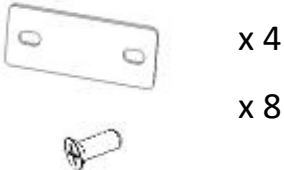

3. (2) Anchor Brackets + (8) M8x20 Hex Head Screws

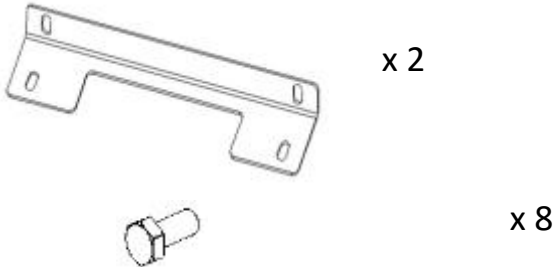

Getting Started

Tools Required

1. Utility Knife
 - a. For removing stretch wrap from around cabinet
2. 13 mm Socket Wrench
 - a. For removing shipping brackets securing cabinet to pallet
3. 8 mm Socket Wrench
 - a. For adjusting equipment mounting rails
4. 13 mm Open-end Wrench
 - a. For adjusting leveling feet
5. #2 Phillips Screwdriver
 - a. For adjusting leveling feet
 - b. For installing screws to secure equipment in mounting rails
 - c. For removing and installing door hinges
 - d. For installing baying brackets

Unpacking Notifications



CAUTION: The EF-Series EuroFrame Gen 2 Cabinet is heavy. Use a minimum of two (2) people to unpack and remove the cabinet from the pallet.



CAUTION: The EF-Series EuroFrame Gen 2 casters are for moving the cabinet short distances over smooth floor surfaces only. Move shipping pallet as close as possible to the final installation location before unpacking.



CAUTION: The EF-Series EuroFrame Gen 2 casters are not intended to support cabinet loads for extended periods of time. Always support the cabinet on leveling feet after positioning.

Inspect the cabinet for damage. If any damage to the cabinet is observed, contact your distributor or CPI Customer Service at +44 1628 524-834.

Unpacking

1. Carefully remove the plastic wrap surrounding the cabinet using a utility knife. Be careful not to allow the knife to contact the cabinet, as this may damage the unit.
2. Remove the four (4) cardboard corner protectors.
3. Inspect inside the cabinet to ensure all items are securely fastened to the cabinet. Remove any items that were shipped inside the cabinet that are not fastened to the cabinet.
4. Remove the shipping brackets that anchor the cabinet to the pallet using a 13 mm (1/2") socket wrench.



NOTE: Do not discard the shipping brackets. These brackets are used to anchor the cabinet to the floor. See “Anchoring the cabinet to the floor.”

5. Remove the cabinet from the pallet.



RECYCLABLE MATERIALS: CPI uses only recyclable materials in all of its cabinet packaging. Please save packaging for later use or dispose of properly. All wood components of CPI pallets have been properly treated to comply with the pest-free certifications required by foreign countries.

6. If the cabinet is to be reshipped, save all packaging materials for reuse.



DISCLAIMER: CPI is not responsible for any damage to the cabinet or its contents after the cabinet is repackaged and reshipped.

7. After the cabinet is unpacked, check the cabinet and the hardware kit to insure that all of the components and hardware items have been received with the cabinet.

Contact the CPI European Office or find additional resources on the CPI website:

CPI Customer Service at +44 1628 524-834
www.chatsworth.com

Installation

Moving the Cabinet



CAUTION: The EF-Series EuroFrame Gen 2 Cabinet ships on casters. Move the cabinet by pushing on the front or the rear of the cabinet. Do not push the cabinet from the sides.

The EF-Series EuroFrame Gen 2 Cabinet has been provided with four (4) casters to allow the cabinet to be rolled into position. The standard casters are only intended to support the cabinet when it is empty.

Once the cabinet has been moved to the final location, level and anchor the cabinet per the instructions below.

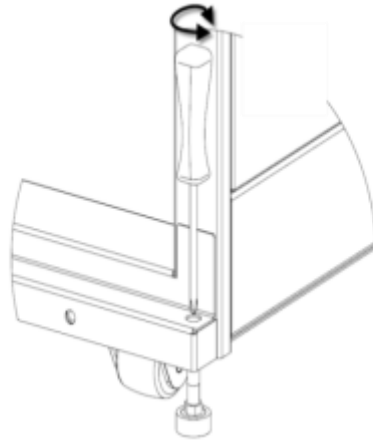

Anchoring the cabinet to the floor

Ensure that the cabinet has been properly leveled. All four (4) leveling feet should be in firm contact with the floor and the cabinet should not rock in any direction. A level placed on the cabinet frame should confirm that the cabinet is level. If the cabinet is not level, adjust the leveling feet with a #2 Phillips screwdriver or 13 mm open-end wrench until the cabinet is level and the cabinet will not rock in any direction.

EuroFrame cabinets, whether bayed together or standalone, should be anchored to the floor. The pallet shipping/floor attachment brackets (shown below) are used to anchor the cabinet to the floor. The brackets attach to the outside of the frame (as they were on the pallet). Installation requires four M10 anchors.



Pallet Shipping/Floor Attachment Bracket

The mounting locations for the brackets are shown in the figure below.

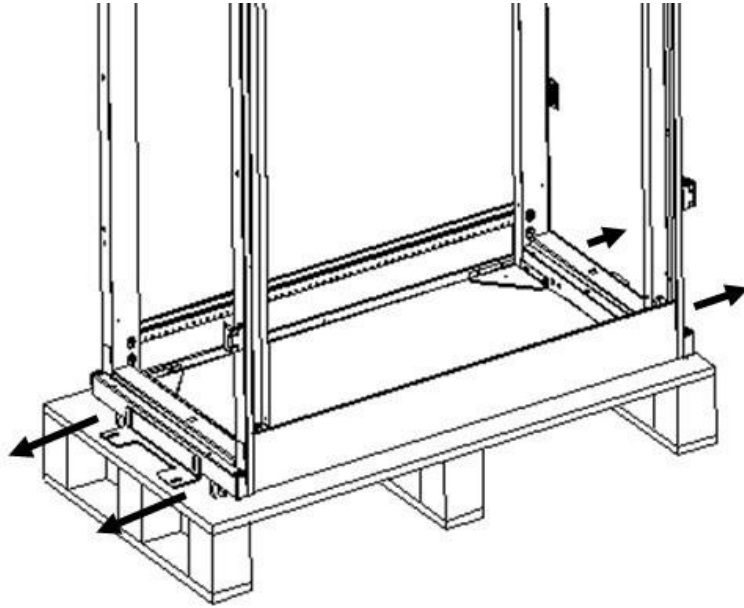

Attach the
M10 hardware appropriate for your type of flooring.

cabinet to the floor with

Bonding the cabinet to the telecommunications ground

EF-Series EuroFrame Gen 2 Cabinets should be bonded to the telecommunications ground. The top panel, side panels, doors and mounting rails on the EuroFrame cabinet are electrically bonded to the frame. A ground strap bonds the panels and doors to the frame. To bond the cabinet to the telecommunications ground, use a One-Hole Ground Terminal Block (P/N 08009-001, ordered separately) or one-hole copper lug with $\frac{1}{4}$ " (M6) or $\frac{3}{8}$ " (M8) hole to connect a bonding conductor to the telecommunications ground or signal reference grid. Attach the block/lug to the cabinet frame using a M6 bolt. Secure the lug to the center thread insert on the inside of the bottom front/rear support on the cabinet.

P/N 08009-001
(ordered separately)

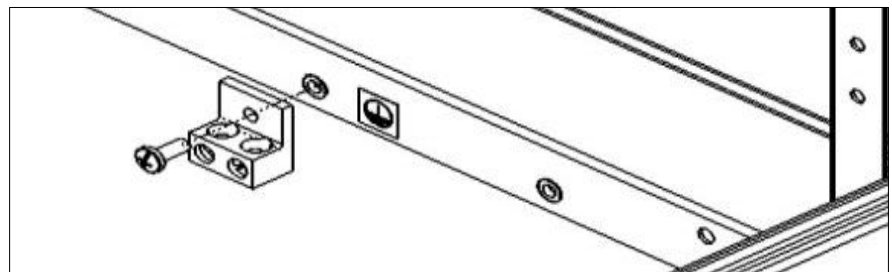

Baying cabinets together

EF-Series EuroFrame Gen 2 Cabinets can be bayed (fastened) together with both side panels in place, with a shared side panel between cabinets, or with no side panels between cabinets, depending on installation requirements. Cabinets must be the same height and depth.

1. The cabinet doors do not need to be removed from the cabinet. The baying bracket and hardware is accessible on the rear with the rear doors fully open. The front door should be opened approximately 90 degrees until the hole in the edge of the front door aligns with the screw used to attach the baying bracket (see below).
2. Use the supplied hardware and a #2 Phillips screwdriver to attach the baying bracket (included in the hardware kit) to the first cabinet. The bracket will bay any two cabinets that are the same height and depth side-by-side.

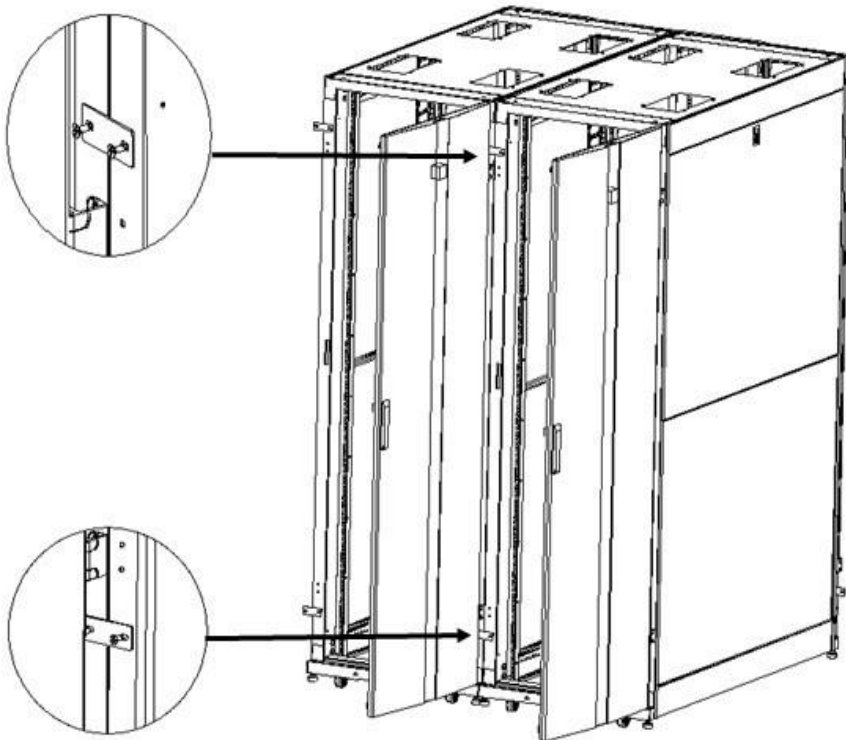

3. Move the second cabinet so that the cabinets are aligned. This may also require adjusting the leveling feet if the second cabinet was not set at the same level as the first cabinet.
4. Use the supplied hardware to attach the baying bracket to the second cabinet.
5. Repeat steps 1-4 for the other end of the cabinet.

Configuring the Cabinet

The EF-Series EuroFrame Gen 2 Cabinet can easily be configured for a variety of applications. Not only can the standard cabinet components be adjusted or removed, but a broad range of accessories can be installed to create a cabinet solution that meets all the needs of your installation requirements.

Removing, Installing and Reversing the Front Door



CAUTION: To avoid personal injury and reduce the risk of damaging the door or the cabinet, one person should support the door, while another person removes the door from the frame.

1. Open the front door approximately 60 degrees.
2. Disconnect the ground wire.
3. While supporting the door, remove the screws that attach the door to the hinge.
4. Pull the door away from the frame.

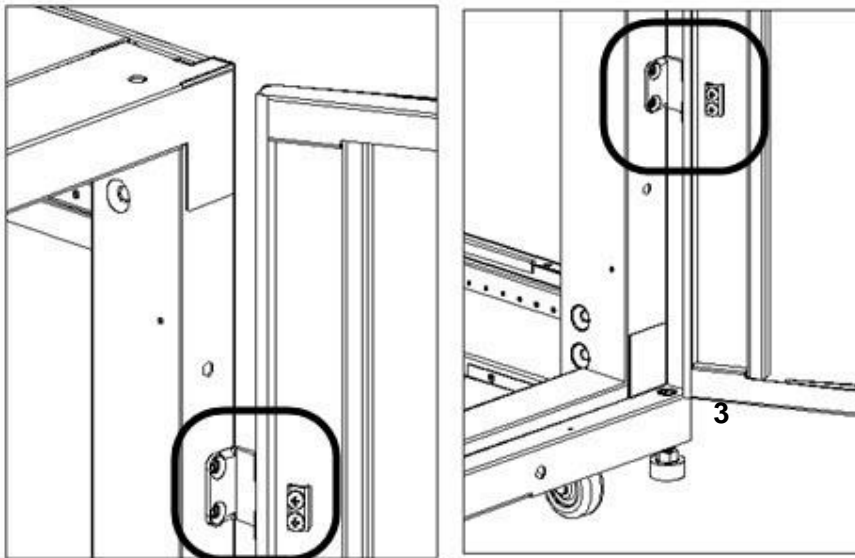

Installing the Front Door:

1. Hold door in partially open position and align hinges on door with hinges on frame.
2. Attach the door to the hinge with screws. Swing the door to check alignment.
3. Reconnect the ground wire.
4. Close Front Door.

Removing and Installing the Rear Doors

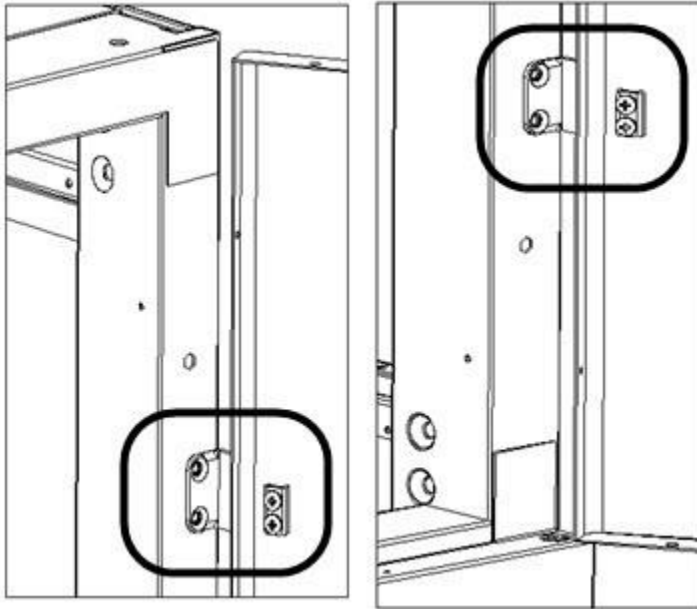

Removing the Rear Doors:

1. Partially open the door, but not as far as 90 degrees.
2. Disconnect the ground wire.
3. Remove the screws that attach the door and hinge to the frame.

Installing the Rear Doors:

1. Hold the door in a 90 degree open position.
2. Align the hinges on the door with the hinges on the frame and secure with screws.
3. Rotate the door partially closed. Check alignment.
4. Reconnect the ground wire.
5. Rotate the door to the closed position.

Removing and Installing the Top Panel

Removing the Top Panel:

1. Open the rear door(s) of the cabinet. Remove the ground wire from the top panel.

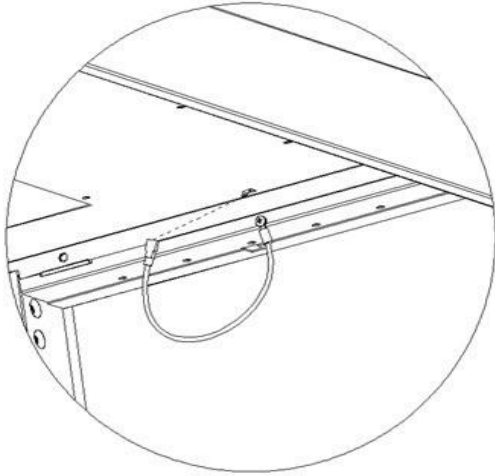

2. Depress and hold the two (2) spring retainers that hold the top panel to the frame. Two shipping screws attaching top panel to frame may need to be removed.

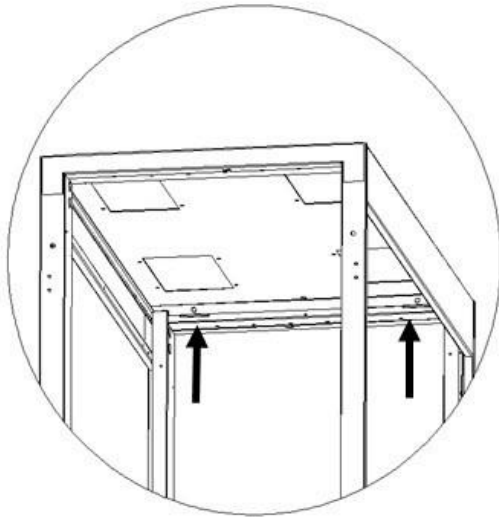

3. Push up on the top panel and remove.

Installing the Top Panel:

1. Align the front edge of the top panel with the frame.
2. Lower the top panel, sliding it forward to make contact with the front of the frame.

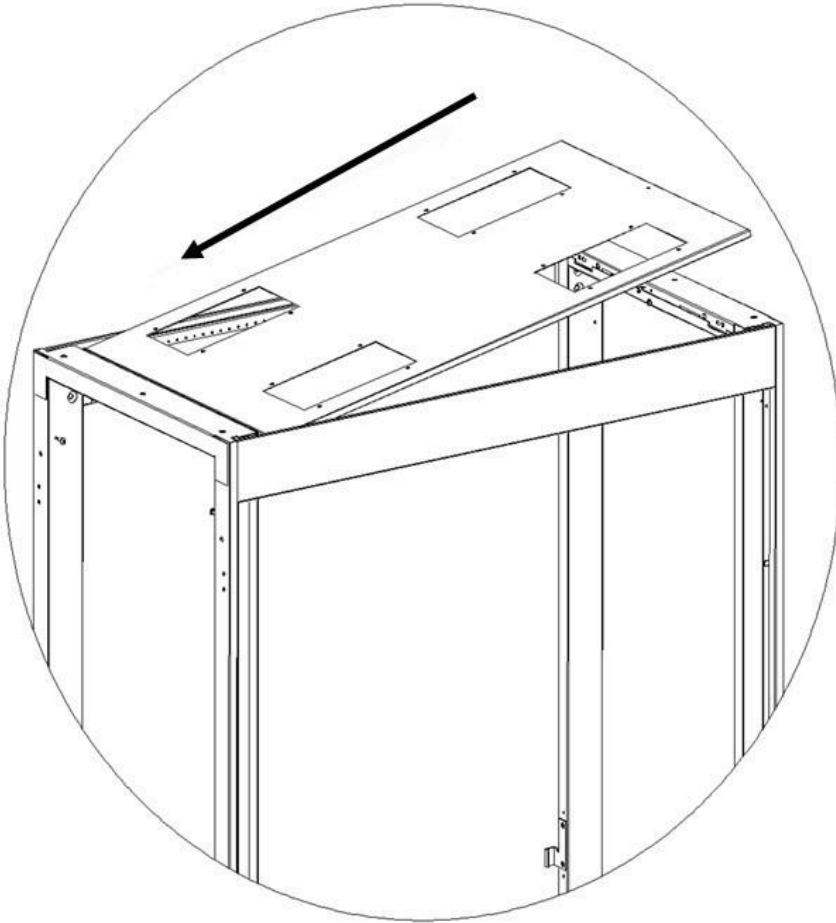

3. Lower the back of the top panel. Ensure that the two (2) spring retainers have snapped in place and secure the top panel from lifting.
4. Reconnect the top panel ground wire.

Removing and Installing the Side Panels

Removing the Side Panels:

1. Unlock the top side panel latch with the key and allow the side panel to tilt away from the cabinet.
2. Disconnect the ground wire between the top and bottom side panel.
3. Lift up on the top side panel and remove it from the cabinet.
4. Disconnect the ground wire between the bottom side panel and the cabinet frame.
5. Remove the bottom side by lifting the side panel and pulling it away from the cabinet.

Installing the Side Panels:

1. Align the bottom side panel with the cabinet frame and slip the side panel into the side of the frame. Allow the side panel to move downwards so that the tabs on the frame engage the upper corners of the side panel.

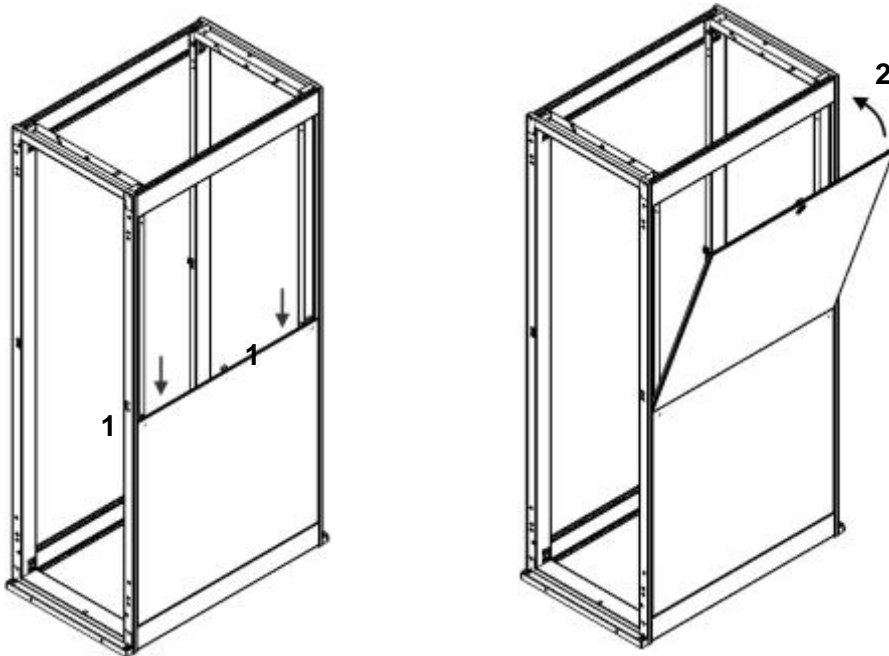

2. Align the top side panel over the bottom side panel and rotate the top side panel up to meet the frame.
3. Lock the side panel with the key.
4. Connect the ground wires between the frame and bottom panel; bottom panel and top panel.

Adjusting the Equipment Rails

1. Use an 8 mm socket wrench to remove the eight (8) screws securing the equipment rail to the frame in four (4) locations. Keep the four (4) paint cutting lock washers on the bottom pairs of screws.

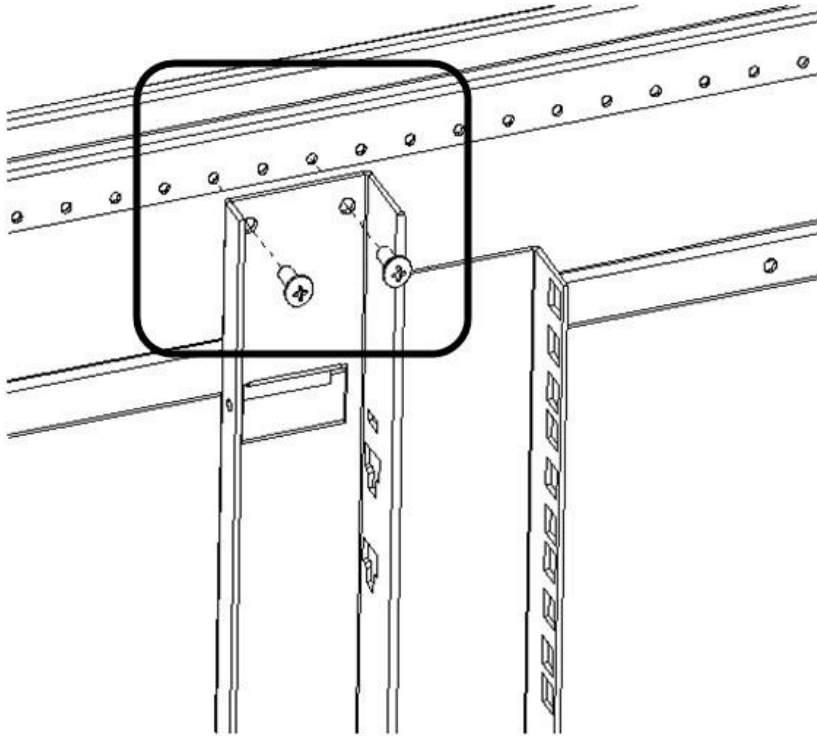

2. Move the equipment rail forward or backward to the desired location.
3. Re-install the four (4) rail mounting screws and four (4) paint cutting lock washers and tighten in all four (4) locations.

Markings are provided on the frame to help align the equipment rails so that they are vertical as well as in the same location as the rails on the opposite side of the frame.

When the equipment rails are located in the first 50 mm (2") at the front (or rear) of the frame, the frame will provide an internal air dam that prevents air from re-circulating to the front of the cabinet.

Installing Equipment

The EF-Series EuroFrame Gen 2 Cabinet supports all manufacturers' equipment that conforms to the EIA/ECA 310E standard. Most equipment attaches directly to the equipment mounting rails; however, some manufacturers may provide brackets or slide assemblies that require additional installation.

Rack-mount unit (U) markings are clearly printed on the equipment rails to simplify installation of components. Align equipment with the U markings on each side of the cabinet before securing the equipment.



NOTE: Equipment rails should be adjusted to the desired location (front to rear) prior to installing equipment. See "Adjusting the Equipment Rails" on page 18.

Hardware is available for purchase (see "Other Accessories").



Cable Management

CPI cable management products provide the proper cable bend radii for better data transmission; fewer tangled cords and cable damage; and ease in moving, adding, and changing connections. The products assist in complying with ANSI/TIA/EIA installation of Category 5/5e/6/6a and fiber cables.

Separate the cables by type, gather into bundles, and fasten loosely with hook and loop fasteners. CPI offers Saf-T-Grip Straps to fasten cable bundles (P/N 0200X-series).

Accessories

Cable Management

<p>Short Cable Ring Kit for 800 mm (31.5"W) cabinets 68106-X02 set of 8 rings that snap onto equipment rail</p>	 A perspective view of a short, rectangular metal cable ring with a raised lip on one side, designed to snap onto an equipment rail.
<p>Long Cable Ring Kit for 800 mm (31.5"W) cabinets Large 68106-X01 set of 8 rings that snap onto equipment rail</p>	 A perspective view of a long, rectangular metal cable ring with a raised lip on one side, designed to snap onto an equipment rail.

EF-Series EuroFrame Gen 2/Short Finger Cable Manager

for 600 mm (23.6"W) cabinets

42U x 600 - **68110-X00**

45U x 600 - **68110-X01**

47U x 600 - **68110-X02**

Standard Fingers, attaches to equipment rail

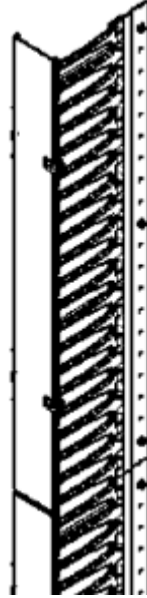

EF-Series EuroFrame Gen 2/Long Finger Cable Manager

for 800 mm (31.5"W) cabinets

42U x 800 - **68120-X00**

45U x 800 - **68120-X01**

47U x 800 - **68120-X02**

Extended Fingers, attaches to equipment rail



Cable Lashing Bracket Kit

125 mm W

42U - **68403-X00**

45U - **68403-X01**

47U - **68403-X02**

Full height bracket

Attaches to the cabinet frame



Accessories

Power Management

PDU brackets are available as well as a wide range of power strips and intelligent PDUs, including basic, metered, monitored and switched versions.

PDU Bracket

Attaches to the cabinet frame

42U, Single – **68140-X00**

42U, Double – **68141-X00**

45U, Single – **68140-X01**

45U, Double – **68141-X01**

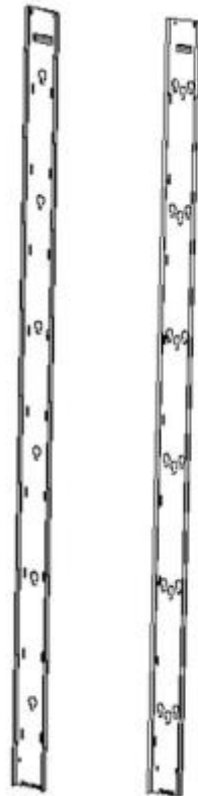

47U, Single – **68140-X002**

47U, Double – **68141-X02**



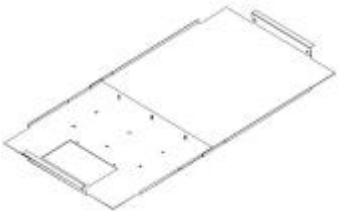

Accessories



Thermal Management

<p>Bottom Panel Seals bottom of cabinet</p> <p>800 x 800 - 68130-X08 800 x 1000-1200 - 68130-X11 800 x 1000-1200 - 68130-X03</p>	
<p>Snap-In Filler Panel</p> <p>1U x 19 EIA, Black (6) - 34537-001 2U x 19 EIA, Black (6) - 34538-001</p> <p>1U x 19 EIA, Black (50) - 34537-002 2U x 19 EIA, Black (50) - 34538-002</p>	

Accessories

Shelves, Trays and other accessories

<p>Cage Nuts & Screws (25) M6 cage nuts and screws</p>	<p style="text-align: right;">12637-001</p> 
<p>Low Profile Fixed Shelf 1U x 19"W</p>	<p style="text-align: right;">26573-719</p> 
<p>Rack-Mount Cable Shelf 1U x 19"W Brush sealed openings on front for cable pass-through</p>	<p style="text-align: right;">13517-701</p> 

<p>Concrete Floor Installation Kit, Four (4) floor anchors</p> <p>M10 - 40604-004</p>	
<p>Caster Kit 26313-001</p> <p>Set of (4) casters – two (2) swivel And two (2) rigid casters</p>	

Service Parts

<p>Square-Punched Equipment Mounting Rails</p> <p>One RH rail + one LH rail</p> <p>600 x 42U - 68325-X00 800 x 42U - 68326-X00 600 x 45U - 68325-X01 800 x 45U - 68326-X01 600 x 47U – 68325-X02 800 x 47U - 68326-X02</p>	
--	--

Front Door
Perforated Metal

600 x 42U - **68340-X00**
800 x 42U - **68340-X06**
600 x 45U - **68340-X01**
800 x 45U - **68340-X07**
600 x 47U - **68340-X02**
800 x 47U - **68340-X08**



Double Rear Door
Perforated Metal

600 x 42U - **68350-X00**
800 x 42U - **68350-X06**
600 x 45U - **68350-X01**
800 x 45U - **68350-X07**
600 x 47U - **68350-X02**
800 x 47U - **68350-X08**



Standard Top Panel

600 x 1000 - **68380-X01**
600 x 1200 - **68380-X03**
800 x 1000 - **68380-X09**
800 x 1200 - **68380-X11**

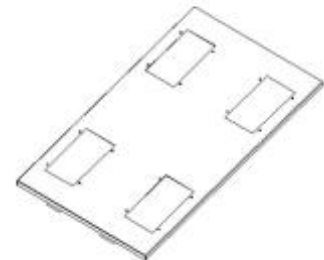

Side Panel

For one side of the cabinet

- 42U x 800 - **68330-X00**
- 42U x 1000 - **68330-X01**
- 42U x 1100 - **68330-X02**
- 42U x 1200 - **68330-X03**
- 45U x 800 - **68330-X04**
- 45U x 1000 - **68330-X05**
- 45U x 1200 - **68330-X07**
- 47U x 800 - **68330-X08**
- 47U x 1000 - **68330-X09**
- 47U x 1200 - **68330-X11**

