

Raised Floor Grommet

CPI's Raised Floor Grommet features a dual-layer brush with an integrated EPDM membrane that forms a superior seal around cable bundles.



ADVANTAGES

- ➔ Split design allows for retrofitting over existing cable bundles in access floor tiles.
- ➔ Economical and effective solution promotes efficient airflow management.
- ➔ Special EPDM membrane between nylon filament brushes provides added sealing capacity around cables.
- ➔ Grommet materials resist breaking, deformation and wear for repeated use.

KEY FEATURES

- Split design does not capture or disrupt existing cables and is ideal for new and retrofit applications
- EPDM membrane between two layers of nylon brushes forms a superior seal around cable bundles
- Durable sealing materials will not break, tear or deform from repeated use
- Available as singles or in carton of 10

SPECIFICATIONS

Application	Designed to seal cable bundles passing through cutouts in data center raised floor environments.
Use	For indoor use only, in environmentally controlled areas. May not be used outdoors or in harsh environments.
Materials	Two-piece grommet frame is UL94 V-0 ABS
	Dual-layer brush filaments are nylon
	Membrane is EPDM (synthetic elastomer)
Dimensions	Above floor: 10.75" x 8.25" (273 mm x 210 mm)
	Recommended floor opening: 9.25" x 6.75" (235mm x 171mm) cutout
Cable Capacity	Use CPI's Cable Fill Table to determine your product cabling needs: http://www.chatsworth.com/cablefill

RELATED ACCESSORIES

- Snap-In Filler Panels
- Seal Kit for Cabinets

SUPERIOR AIRFLOW MANAGEMENT

Chatsworth Products (CPI) Raised Floor Grommet is designed to seal new or existing cable penetrations in data center raised floor environments. The split two-piece design allows for installation along the edge of a raised floor tile. This approach does not "capture" cables and allows for quick tile removal without disrupting your network.

The dual-layer brush design with integrated EPDM flexible membrane provides a superior seal that increases cooling efficiency by greatly reducing bypass airflow. This EPDM layer provides an additional level of sealing effectiveness over traditional, brush-only designs.

Global Availability

US & Canada

+1-800-834-4969
 Toronto, Ontario, Canada
 +905-850-7770
 chatsworth.com
 techsupport@chatsworth.com

Latin America

+52-55-5203-7525
 Toll Free within Mexico
 01-800-01-7592
 chatsworth.com.co

Europe

+44-1628-524-834
 chatsworthproducts.co.uk

Middle East & Africa

Dubai, UAE
 +971-4-2602125
 chatsworth.ae

Asia Pacific

+86 21 6880-0266
 chatsworth.com.cn



CHATSWORTH
 PRODUCTS

ORDERING INFORMATION



Raised Floor Grommet

- Split design does not capture or disrupt existing cables and is ideal for new and retrofit applications
- Available as singles or in carton of 10
- Convenient floor tile cut template included with installation instructions
- Includes (4) self-drilling #8 pan-head screws

Part Number	Description	Shipping Weight lb (kg)
13671-001	Raised Floor Grommet, Each	2 (1.4)
13671-002	Raised Floor Grommet, Pack of 10	18 (8.2)

PRODUCT DIMENSIONS

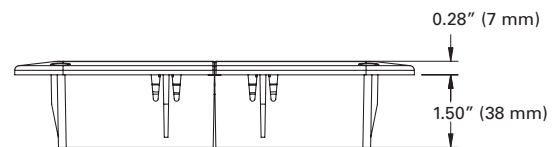
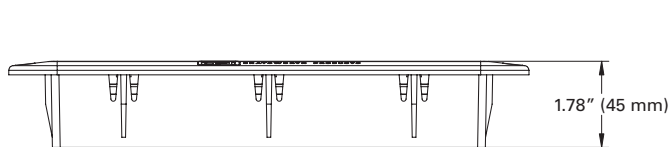
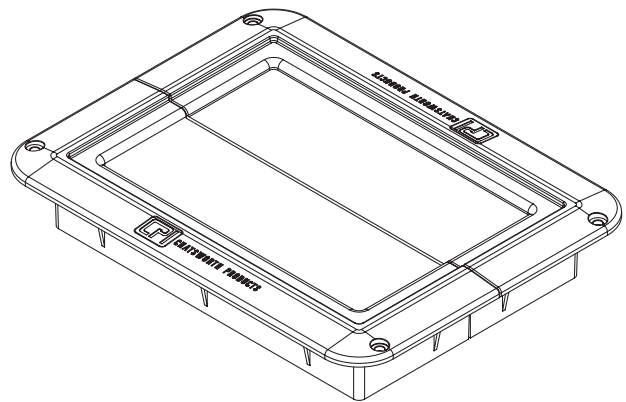
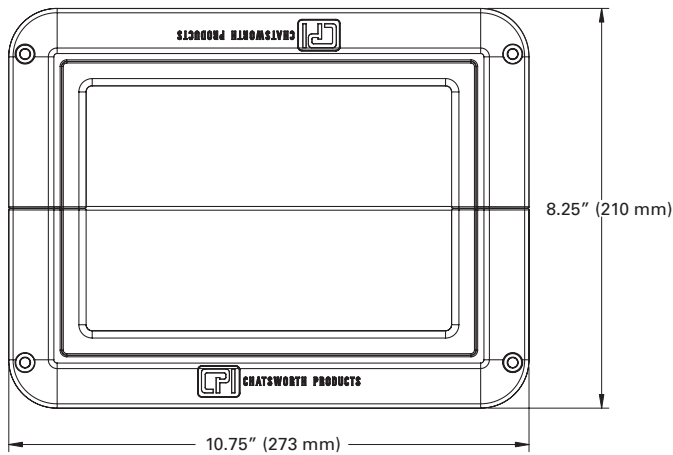

Interested in learning more about our Thermal Management? Call us at 800-834-4969, or email Technical Support at techsupport@chatsworth.com.



CPI now offers Extended Limited Warranties on CPI-Branded Electronic products, available for two additional years beyond the expiration of the Original Warranty Period (3 years).

Contact CPI Customer Service, or visit www.chatsworth.com/warranty for more information.



CHATSWORTH PRODUCTS

While every effort has been made to ensure the accuracy of all information, CPI does not accept liability for any errors or omissions and reserves the right to change information and descriptions of listed services and products.
 ©2017 Chatsworth Products, Inc. All rights reserved. Chatsworth Products, CPI, CPI Passive Cooling, eConnect, RMR, MegaFrame, Saf-T-Grip, SeismicFrame, SlimFrame, TeraFrame, GlobalFrame, CUBE-IT PLUS, Evolution, OnTrac, QuadraRack and Velocity are federally registered trademarks of Chatsworth Products. Simply Efficient, Secure Array, EuroFrame, Click-Nut and Motive are trademarks of Chatsworth Products. All other trademarks belong to their respective companies. 03/17 MKI-60020-684